



# CM360SH

Technical Datasheet  
for Post-installed rebar connections

**Figure A1:**

Overlap joint for rebar connections slabs and beams

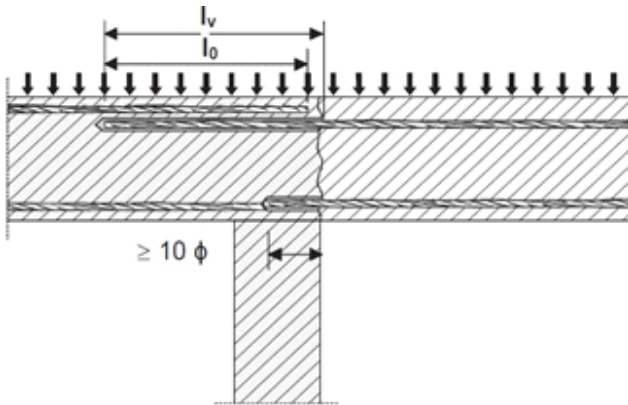

**Figure A2:**

Overlap joint at a foundation of a column or wall where the rebar is stressed in tension

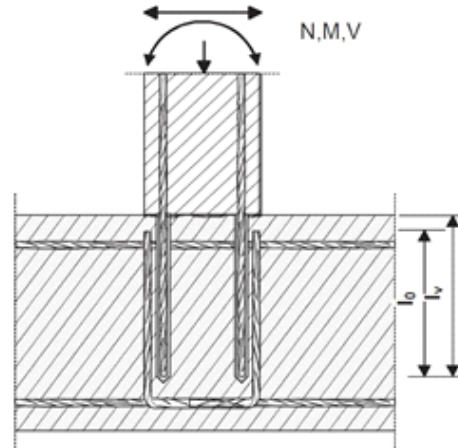

**Figure A3:**

End anchoring of slabs or beams, designed as simply supported

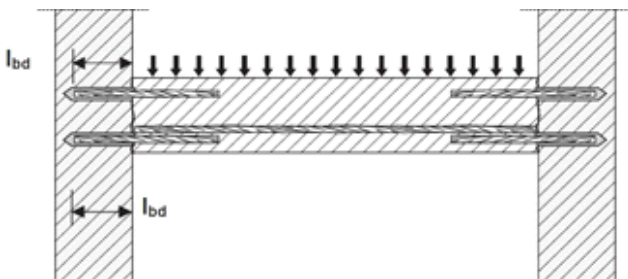

**Figure A4:**

Rebar connection for components stressed primarily in compression. The rebar is stressed in compression

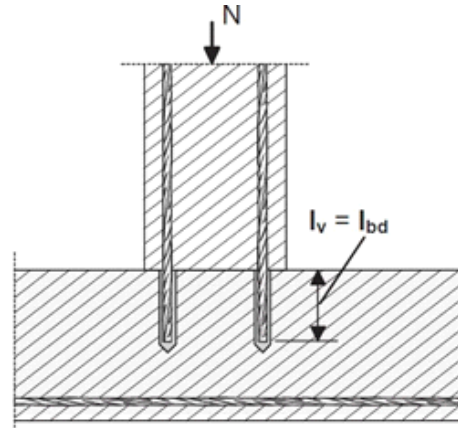

**Figure A5:**

Anchoring of reinforcement to cover the line of acting tensile force

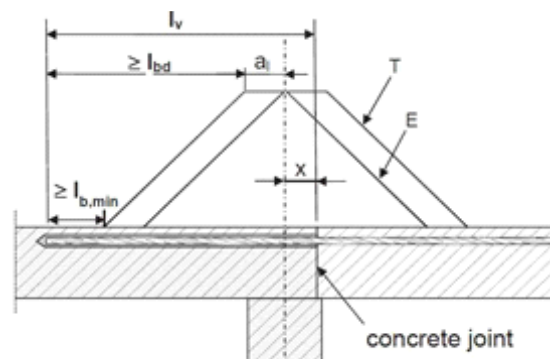

(only post-installed rebar is plotted)

**Key to Figure A5**

T Acting tensile force

E Envelope of  $M/z + N/d$   
(see EN 1992-1-1, Figure 9.2)

X Distance between the theoretical point of support and concrete joint

**Note to Figure A1 to A5:**

In the Figures no transverse reinforcement is plotted, the transverse reinforcement as required by EN 1992-1-1 shall be present.

The shear transfer between old and new concrete shall be designed according to EN 1992-1-1.

**Coaxial cartridge**

ICFS CM SH, Fading blue, Tropical, Tropical Fading blue

410 ml  
420 ml



**Side by side cartridge**

ICFS CM SH, Fading blue, Tropical, Tropical Fading blue

360 ml

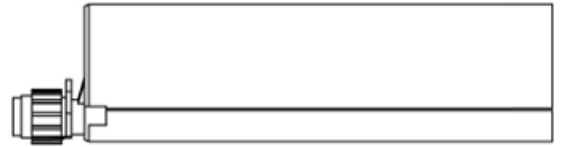

**Two part foil in a single piston component cartridge**

ICFS CM SH, Fading blue, Tropical, Tropical Fading blue

300 ml



**Marking of the mortar cartridges**

Identifying mark of the producer, Trade name, Charge code number, Storage life, Curing and processing time

**Mixing nozzle**

**MN 300**



**CMWN**

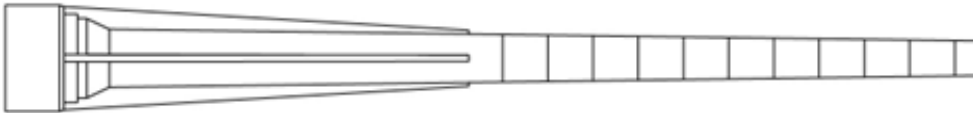

**EZ-Flow**



**MN 400**

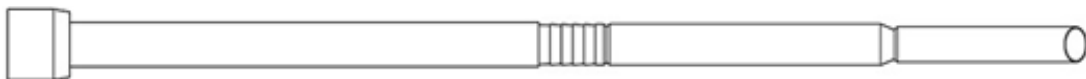

Rebar Ø8, Ø10, Ø12, Ø14, Ø16, Ø18, Ø20, Ø22, Ø24, Ø25, Ø26, Ø28, Ø32

Figure A6:

Reinforcing bar



Minimum value of related rib area  $f_{R,min}$  according to EN 1992-1-1:2004.

The maximum outer rebar diameter over the ribs shall be:

Nominal diameter of the rib  $d + 2 \cdot h$  ( $h \leq 0,07 \cdot d$ )

(d: nominal diameter of the bar; h: rib height of the bar)

Table A1:

Materials

Product Form		Bars and de-coiled rods	
		B	C
Class		B	C
Characteristic yield strength $f_{yk}$ or $f_{0,2k}$ (MPa)		400 to 600	
Minimum value of $k = (f_t / f_{yk})_k$		$\geq 1,08$	$\geq 1,15$ < 1,35
Characteristic strain at maximum force $\epsilon_{uk}$ (%)		$\geq 5,0$	$\geq 7,5$
Bendability		Bend / Rebend test	
Maximum deviation from nominal mass (individual bar) (%)	Nominal bar size (mm)		
	$\leq 8$ > 8	$\pm 6,0$ $\pm 4,5$	
Bond: Minimum relative rib area, $f_{R,min}$	Nominal bar size (mm)		
	8 to 12 > 12	0,040 0,056	

### Specifications of intended use

#### Anchorage subject to:

- Static and quasi-static load.
- Fire exposure

#### Base materials

- Reinforced or unreinforced normal weight concrete according to EN 206:2013
- Strength classes C12/15 to C50/60 according to EN 206:2013.
- Maximum chloride concrete of 0,40% (CL 0.40) related to the cement content according to EN 206:2013.
- Non-carbonated concrete

#### Note:

In case of a carbonated surface of the existing concrete structure the carbonated layer shall be removed in the area of the post installed rebar connection (with a diameter  $d_s + 60$  mm) prior to the installation of the new rebar. The depth of concrete to be removed shall correspond to at least minimum concrete cover in accordance with EN 1992-1-1.

The foregoing may be neglected if building components are new and not carbonated.

**Temperature range :**

- -40°C to +80°C (max. short. term temperature +80°C and max. long term temperature +50°C)

**Use conditions (Environmental conditions)**

- The rebars may be used in dry or wet concrete.

**Design :**

- The anchorages are designed under the responsibility of an engineer experienced in anchorages and concrete work.
- Verifiable calculation notes and drawings are prepared taking account of the forces to be transmitted.
- Design according to EN 1992-1-1 and EN 1992-1-2.
- The position of the reinforcement in the existing structure shall be determined on the basis of the construction documentation and taken into account when designing

**Installation:**

- Dry or wet concrete.
- It must not be installed in flooded holes.
- Hole drilling by hammer, drill dustless drill, compressed air drill mode or diamond core drilling.
- The installation of post-installed rebars shall be done only by suitable trained installer and under supervision on site. The conditions under which an installer may be considered as suitable trained and the conditions for supervision on site are up to the Member States in which the installation is done.
- Check the position of the existing rebars (if the position is not known, it shall be determined using a rebar detector suitable for this purpose).

**Figure B1:**

General design rules of construction for bonded-in rebars

- Only tension forces in the axis of the rebar may be transmitted
- The transfer of shear forces between new concrete and existing structure shall be designed additionally according to EN 1992-1-1.
- The joints for concreting must be roughened to at least such an extent that aggregate protrude. member edge

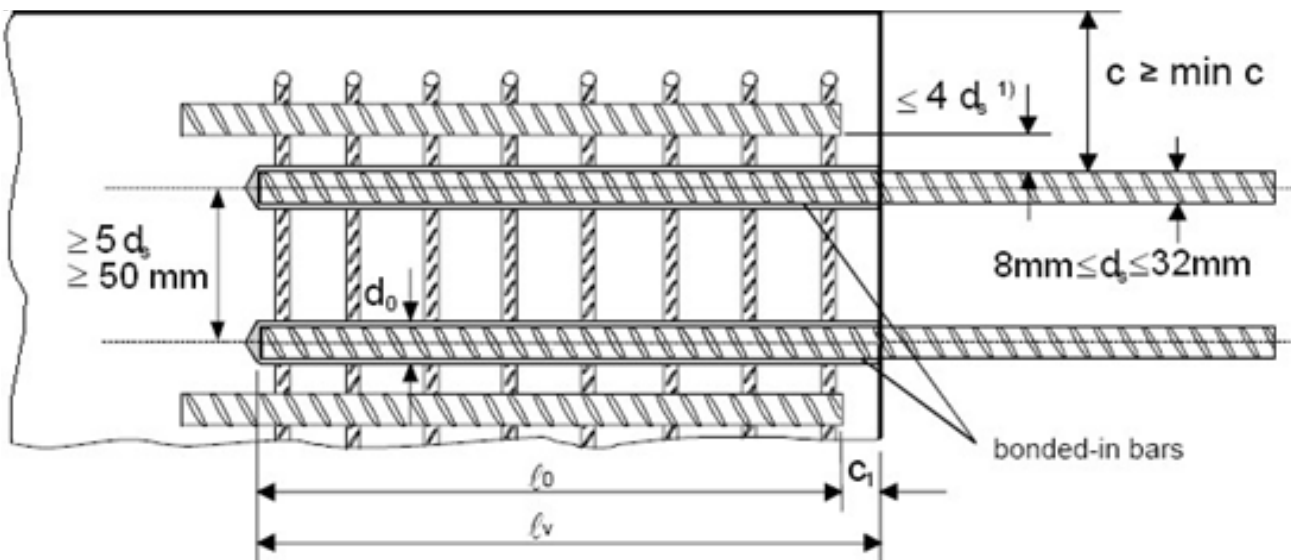

<sup>1)</sup> If the clear distance between lapped bars exceeds  $4d_s$  then the lap length shall be increased by the difference between the clear bar distance and  $4d_s$



- c** concrete cover of bonded-in bar
- c<sub>1</sub>** concrete cover at end-face of bonded-in bar
- min c** minimum concrete cover acc. Table B1 of this assessment dsdiameter of bonded-in bar
- d<sub>s</sub>** diameter of bonded-in bar
- ℓ<sub>0</sub>** lap length acc. to EN 1992-1-1:2004
- ℓ<sub>v</sub>** effective embedment depth  $\geq \ell_0 + c_1$
- d<sub>0</sub>** nominal drill bit diameter, see Table B2

**Table B1**

**Minimum concrete cover c<sub>min</sub> depending on drilling method**

Drilling method	Bar diameter $\phi$	Without drilling aid $c_i$	With drilling aid $c_i$
Hammer drilling or dustless drilling or diamond drilling	< 25 mm	30 mm + 0,06 $\ell_v \geq 2 \phi$	30 mm + 0,02 $\ell_v \geq 2 \phi$
	$\geq 25$ mm	40 mm + 0,06 $\ell_v \geq 2 \phi$	40 mm + 0,02 $\ell_v \geq 2 \phi$
Compressed air drilling	< 25 mm	50 mm + 0,08 $\ell_v$	50 mm + 0,02 $\ell_v$
	$\geq 25$ mm	60 mm + 0,08 $\ell_v \geq 2 \phi$	60 mm + 0,02 $\ell_v \geq 2 \phi$

**Figure B2:**

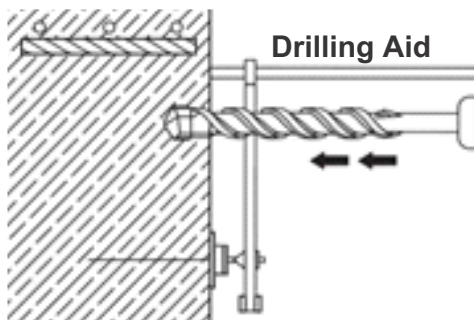

**Example of drilling aid**

Minimum anchorage length  $\ell_{bd,PIR}$  and minimum anchorage lap length  $\ell_{0,PIR}$

**Minimum anchorage length**

$$\ell_{b,PIR} = \alpha_{lb} \cdot \ell_{b,min}$$

$\alpha_{lb} = \alpha_{lb,100y}$  = amplification factor for minimum anchorage length  
 (see Annex C 1, Table C2 for hammer or dustless drilling method)  
 (see Annex C 2, Table C4 for diamond core drilling method)

$\ell_{b,min}$  = minimum anchorage length of cast-in rebar according to EN 1992-1-1, eq. 8.6

**Minimum lap length**

$$\ell_{0,PIR} = \alpha_{lb} \cdot \ell_{0,min}$$

$\alpha_{lb} = \alpha_{lb,100y}$  = amplification factor for minimum anchorage length  
 (see Annex C 1, Table C2 for hammer or dustless drilling method)  
 (see Annex C 2, Table C4 for diamond core drilling method)

$\ell_{0,min}$  = minimum lap length of cast-in rebar according to EN 1992-1-1, eq. 8.11

**Table B2**

**Drilling diameter and maximum anchorage depth**

Rebar diameter $d_{nom}^{1)}$	Nominal drilling diameter $d_{ut}$	Max permissible embedment depth $l_{v,max}$
[mm]	[mm]	[mm]
8	12(10)	400
10	14 (12)	500
12	16	600
14	18	700
16	20	800
18	22	900
20	25	1000
22	28	1000
24	32	1000
25	32	1000
26	32	1000
28	35	1000
32	40	1000

1) The maximum outer rebar diameter over the ribs shall be:  
nominal diameter of the bar  $d_{nom} + 0,20 d_{nom}$

**Table B3**

**Processing and Load time**

ICFS CM SH, ICFS CM SH Fading blue			
Resin cartridge temperature [°C]	T Work [mins]	Base material Temperature [°C]	T Load [mins]
+10	30 mins	-10 to -5	24 hours
+5	20mins	-5 to 0	300mins
0 to +5	15 mins	0 to +5	210 mins
5 to 10	10 mins	+5 to 10	145 mins
+10 to +15	8 mins	+10 to +15	85 mins
+15 to 20	6 mins	+15 to 20	75 mins
+20 to 25	5 mins	+20 to 25	50 mins
+25 to +30	4 mins	+25 to +30	40 mins

ICFS CM SH Tropical, ICFS CM SH Tropical Fading blue			
Resin cartridge temperature [°C]	T Work [mins]	Base material Temperature [°C]	T Load [mins]
+15 to 20	15 mins	+15 to +20	5 hours
+15 to +25	10 mins	+20 to +25	145 mins
+15 to +30	7.5 mins	+25 to +30	85 mins
+15 to +35	5 mins	+30 to +35	50 mins
+15 to +40	3.5 mins	+35 to +40	40 mins

**Table B4**

**Applicator gun**

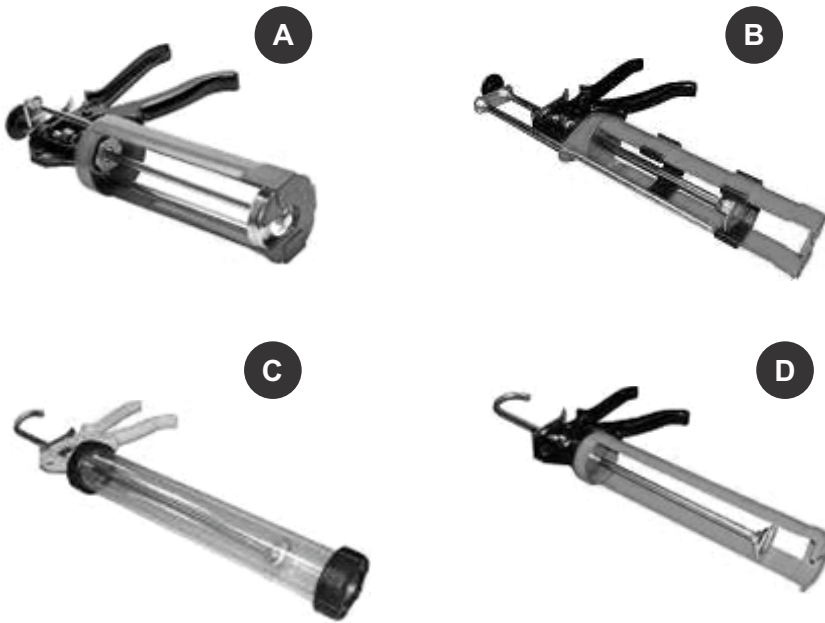

Applicator gun	Cartridge	
A	Coaxial	410ml 420ml
B	Side by side	360ml
C	Foil capsule	300ml
D	Foil capsule	300ml



**Table B5**

**Brush**

Sizes	Ø8	Ø10	Ø12	Ø14	Ø16	Ø18	Ø20	Ø22	Ø24	Ø25	Ø26	Ø28	Ø32
Drill hole diameter do [mm]	12(10)	14(12)	16	18	20	22	25	28	32	32	32	35	40
Brushes head diameter [mm]	14	14	19	22	22	24	29	31	40	40	40	40	42
Brushes head length [mm]	75												

If required use additional accessories and extension for air nozzle and brush to reach back of hole

Max. hole depth	Brush / extension configuration	Part
250 mm	Standard brush	(a)
550 mm	Brush head unit + handle unit	(b)+(c)
850 mm	Brush head unit + extension piece + handle unit	(b)+(d)+(c)
1150 mm	Brush head unit + 2x extension piece + handle unit	(b)+(d)+(d)+(c)

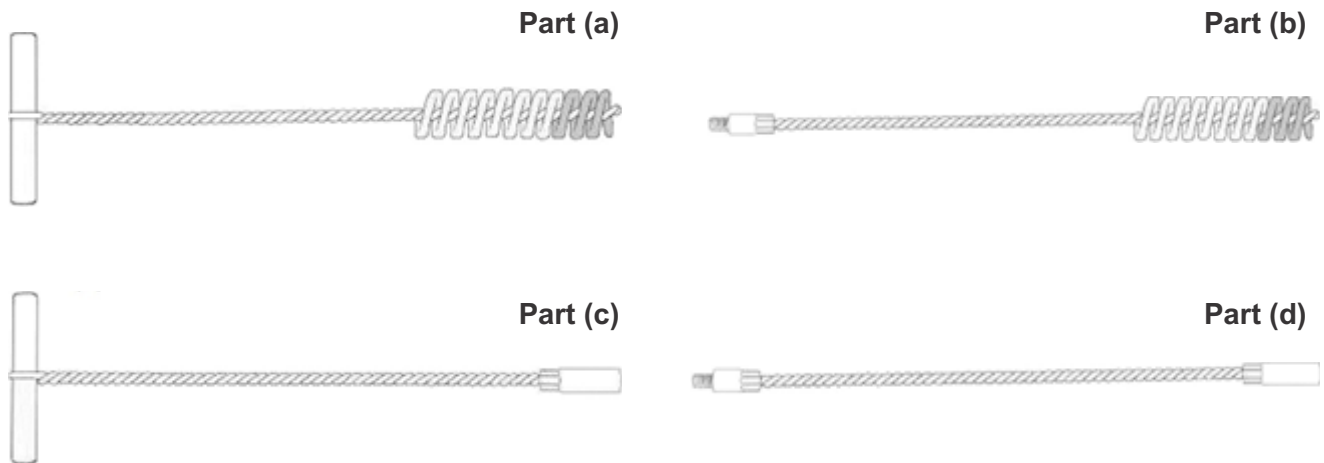

**Table B6**

**Extension hose for deep holes**

Sizes	Ø8	Ø10	Ø12	Ø14	Ø16	Ø18	Ø20	Ø22	Ø24	Ø25	Ø26	Ø28	Ø32
Hole diameter [mm]	10	12	16	18	20	22	25	28	32	32	32	35	40
Extension hose [mm]	9			14									
Resin stopper [mm]	-	-	-	-	18	22	30	30	30	30	30	30	36

## Drilling the hole

**Drill hole to the require embedment depth using one of the following:**

- Hammer drill (HD) with a carbide drill bit set in rotation hammer mode
- Hammer drill with the specified hollow drill bit (HDB) set in hammer mode
- Core drill machine with a diamond core drill bit (DD)
- Compressed air drilling (CA)

**Before drilling remove carbonized concrete.**

**In case of aborted drill hole the drill hole shall be filled with mortar.**



Rotary hammer  
drilling

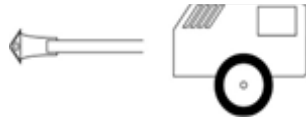

Compressed air  
drill

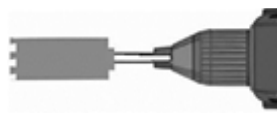

Diamond core  
drilling

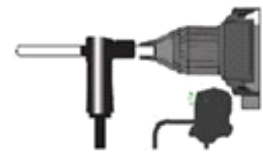

Hollow drill bit  
(Dustless drilling)

## HDB – Hollow Drill Bit System

**Heller Duster Expert hollow drill bit**

- SDS-Plus  $\leq 16\text{mm}$
- SDS-Max  $\geq 16\text{mm}$

**Class M vacuum**

- Minimum flow rate  $266\text{ m}^3/\text{h}$  ( $74\text{ l/s}$ )

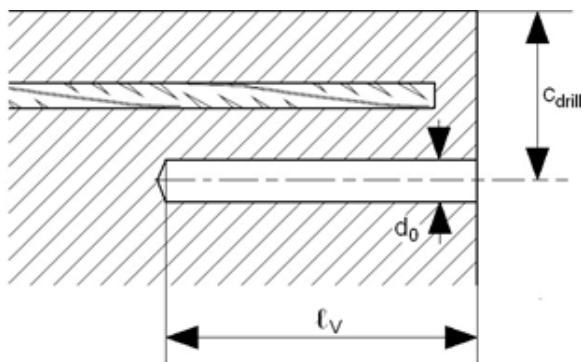

- Observe concrete coverage  $c$ , as per setting plan and Table B1
- Drill parallel to the edge and to existing rebar

- $C_{\text{drill}}$  = centre of the drilling from concrete coverage
- $d_0$  = nominal drill bit diameter
- $d_s$  = diameter of bonded-in rebar
- $f_y$  = yield strength of reinforcement
- $f_t$  = tensile strength of reinforcement

## Cleaning the hole

The borehole must be free of dust, debris, water, ice, oil, grease and other contaminants prior to mortar injection.

### Hammer drilling (HD) or Compressed air drilling (CA)

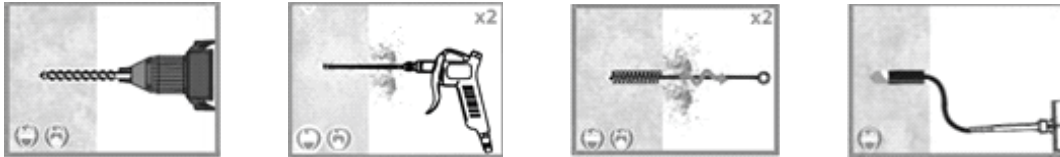

1. After drilling the hole, blow 2 times from the back of the hole with oil-free compressed air (min. 6 bar) until return air stream is free of noticed dust. A manual pump may be used for a drill depth of < 300 mm and for drill holes not larger than 20 mm diameter. Repeat this action twice.
2. Selecting the appropriate brush and extension, if necessary, insert the brush to the bottom of the hole and firmly withdraw with a twisting motion. There should be positive interaction between the bristles of the brush and the side of the hole otherwise a new brush should be chosen. Repeat this action twice.
3. Repeat operation 1 and 2.
4. Perform the blowing operation 1 time again with compressed air until return air stream is free of noticeable dust.

### Diamond core drilling (DD)

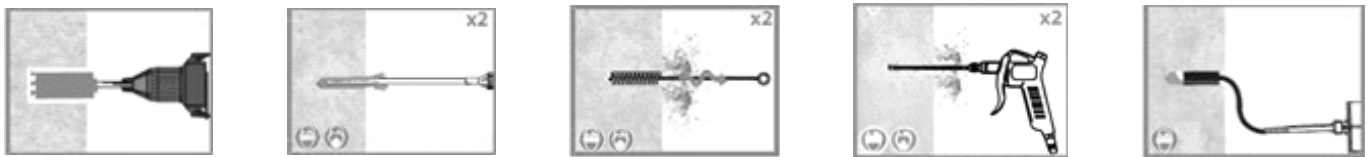

1. After drilling the hole, starting from the back of the hole, flush with pressurised water a minimum of two times and until there is only clean water.
2. Selecting the appropriate brush and extension, if necessary, insert the brush to the bottom of the hole and firmly withdraw with a twisting motion. There should be positive interaction between the bristles of the brush and the side of the hole otherwise a new brush should be chosen. Perform the brushing operation twice.
3. Repeat operation 1 and 2.
4. Blow 2 times from the back of the hole with oil-free compressed air (min. 6 bar) until return air stream is free of noticed dust. Repeat this action twice.

### Hammer drilling with hollow drill bit (HDB)



1. Use the specified hollow drill bit and follow the manufacturers instruction. Ensure the vacuum system is on.
2. After drilling the hole, perform a visual inspection to ensure the system has worked correctly and that no debris remains.
3. No further cleaning process is necessary.

## Mortar injection

If the hole collects water after initial cleaning, this water must be removed before injecting the resin.

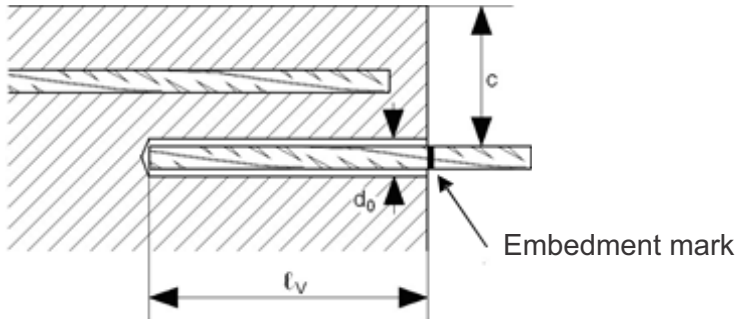

Before use, make sure the rebar is dry and free of oil or other residue. Mark embedment depth on the rebar (e.g. with tape)  $l_v$ . Insert rebar in borehole, to verify hole and setting depth  $l_v$ .

- **Check expiration date:**

See imprint on cartridge. Do not use an expired product

- **Foil pack temperature:**

Must be between +5°C and +40°C when in use

- **Base material temperature at time of installation:**

Must be between +5°C and +40°C

- **Instructions for transport and storage:**

Keep in a cool, dry and dark place at +5°C to +20°C achieve maximum shelf life

Select the appropriate static mixer nozzle for the installation, open the cartridge/foil and screw onto the mouth of the cartridge.

Insert the cartridge into the correct applicator gun.



Extrude the first part of the cartridge to waste until an even colour has been achieved without streaking in the resin

If necessary, cut the extension tube to the depth of the hole and push onto the end of the mixer nozzle and (for rebars 16 mm dia. or more) fit the correct resin stopper to the other end.

Attach extension tubing and resin stopper.

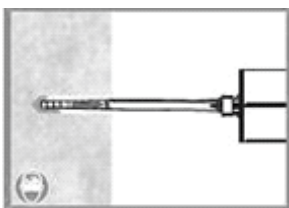

Insert the mixer nozzle (resin stopper / extension tube if applicable) to the bottom of the hole. Begin to extrude the resin and slowly withdraw the mixer nozzle from the hole ensuring that there are no air voids as the mixer nozzle is withdrawn. Fill the hole to approximately  $\frac{1}{2}$  to  $\frac{3}{4}$  full and remove the mixer nozzle completely.

**Inserting the rebar**

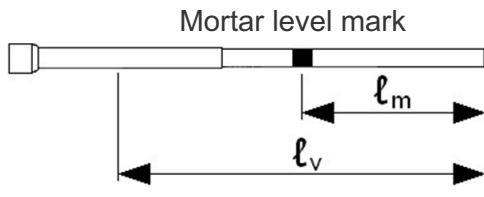

Mark the required mortar level  $l_m$  and embedment depth  $l_v$  with tape or marker on the injection extension.

Quick estimation:  $l_m = 1/2 \cdot l_v$

Continue injection until the mortar level mark  $l_m$  becomes visible.



Insert the rebar, free from oil or other release agents, to the bottom of the hole using a back and forth twisting motion ensuring all the threads are thoroughly coated. Adjust to the correct position within the stated working time.

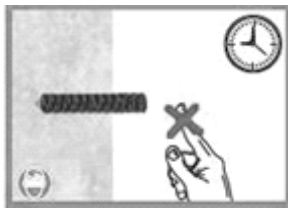

Any excess resin should be expelled from the hole evenly around the steel element showing that the hole is full. This excess resin should be removed from around the mouth of the hole before it sets.

Leave the anchor to cure.

Do not disturb the anchor until the appropriate loading/curing time has elapsed depending on the substrate conditions and ambient temperature.

**Design bond strength of post-installed rebar  $f_{bd,PIR}$  and  $f_{bd,PIR,100y}$  for working life 50 and 100 years**

$$f_{bd,PIR} = k_b \cdot f_{bd}$$

$k_b$  = reduction factor

$f_{bd}$  = design bond strength of cast-in rebar according to EN 1992-1-1

**Table C1**

Values of the design bond strength of post installed rebar  $f_{bd,PIR} = f_{bd,PIR,100y}$  with reduction factor  $k_b = k_{b,100y}$  for hammer drilling or dustless drilling methods for good bond conditions

Rebar Ø 8 to 16									
Concrete class	C12/15	C16/20	C20/25	C25/30	C30/37	C35/45	C40/50	C45/55	C50/60
$k_b$ [-]	1,0	1,0	1,0	1,0	1,0	1,0	1,0	1,0	1,0
$f_{bd,PIR}$ [N/mm <sup>2</sup> ]	1,6	2,0	2,3	2,7	3,0	3,4	3,7	4,0	4,3

Rebar Ø 18									
Concrete class	C12/15	C16/20	C20/25	C25/30	C30/37	C35/45	C40/50	C45/55	C50/60
$k_b$ [-]	1,0	1,0	1,0	1,0	1,0	1,0	1,0	1,0	0,93
$f_{bd,PIR}$ [N/mm <sup>2</sup> ]	1,6	2,0	2,3	2,7	3,0	3,4	3,7	4,0	

Rebar Ø 20									
Concrete class	C12/15	C16/20	C20/25	C25/30	C30/37	C35/45	C40/50	C45/55	C50/60
$k_b$ [-]	1,0	1,0	1,0	1,0	1,0	1,0	1,0	0,92	0,86
$f_{bd,PIR}$ [N/mm <sup>2</sup> ]	1,6	2,0	2,3	2,7	3,0	3,4	3,7		

Rebar Ø 22									
Concrete class	C12/15	C16/20	C20/25	C25/30	C30/37	C35/45	C40/50	C45/55	C50/60
$k_b$ [-]	1,0	1,0	1,0	1,0	1,0	1,0	0,91	0,84	0,79
$f_{bd,PIR}$ [N/mm <sup>2</sup> ]	1,6	2,0	2,3	2,7	3,0	3,4			

Rebar Ø 24 to Ø 26									
Concrete class	C12/15	C16/20	C20/25	C25/30	C30/37	C35/45	C40/50	C45/55	C50/60
$k_b$ [-]	1,0	1,0	1,0	1,0	1,0	0,90	0,82	0,76	0,71
$f_{bd,PIR}$ [N/mm <sup>2</sup> ]	1,6	2,0	2,3	2,7	3,0				

Rebar Ø 28									
Concrete class	C12/15	C16/20	C20/25	C25/30	C30/37	C35/45	C40/50	C45/55	C50/60
$k_b$ [-]	1,0	1,0	1,0	1,0	0,88	0,8	0,73	0,67	0,63
$f_{bd,PIR}$ [N/mm <sup>2</sup> ]	1,6	2,0	2,3	2,7					

Rebar Ø 32									
Concrete class	C12/15	C16/20	C20/25	C25/30	C30/37	C35/45	C40/50	C45/55	C50/60
$k_b$ [-]	1,0	1,0	1,0	0,86	0,76	0,69	0,63	0,58	0,54
$f_{bd,PIR}$ [N/mm <sup>2</sup> ]	1,6	2,0	2,3						

Tabulated values are valid for good bond conditions according to EN 1992-1-1.

For all other bond conditions multiply the values by 0,7.



**Table C2**
**Amplification factor for minimum anchorage length**

Rebar	Amplification factor	Concrete class								
		C12/15	C16/20	C20/25	C25/30	C30/37	C35/45	C40/50	C45/55	C50/60
Ø8 to Ø26	$\alpha_{lb} = \alpha_{lb,100y}$	1,0	1,0	1,0	1,0	1,0	1,0	1,0	1,0	1,0
Ø28		1,0	1,0	1,0	1,0	1,0	1,0	1,0	1,0	1,1
Ø32		1,0	1,0	1,0	1,0	1,0	1,1	1,2	1,3	1,4

**Design bond strength of post-installed rebar  $f_{bd,PIR}$  and  $f_{bd,PIR,100y}$  for working life 50 and 100 years**

$$f_{bd,PIR} = k_b \cdot f_{bd}$$

 $k_b$  = reduction factor

 $f_{bd}$  = design bond strength of cast-in rebar according to EN 1992-1-1

**Table C3**
**Values of the design bond strength of post installed rebar  $f_{bd,PIR} = f_{bd,PIR,100y}$  with reduction factor  $k_b = k_{b,100y}$  for diamond core drilling methods for good bond conditions**

Rebar Ø 8									
Concrete class	C12/15	C16/20	C20/25	C25/30	C30/37	C35/45	C40/50	C45/55	C50/60
$k_b$ [-]	1,0	1,0	1,0	1,0	1,0	1,0	0,91	0,84	0,79
$f_{bd,PIR}$ [N/mm <sup>2</sup> ]	1,6	2,0	2,3	2,7	3,0	3,4			

Rebar Ø 10									
Concrete class	C12/15	C16/20	C20/25	C25/30	C30/37	C35/45	C40/50	C45/55	C50/60
$k_b$ [-]	1,0	1,0	1,0	1,0	1,0	0,90	0,91	0,84	0,79
$f_{bd,PIR}$ [N/mm <sup>2</sup> ]	1,6	2,0	2,3	2,7	3,0		3,4		

Rebar Ø 12									
Concrete class	C12/15	C16/20	C20/25	C25/30	C30/37	C35/45	C40/50	C45/55	C50/60
$k_b$ [-]	1,0	1,0	1,0	1,0	1,0	0,90	0,82	0,76	0,71
$f_{bd,PIR}$ [N/mm <sup>2</sup> ]	1,6	2,0	2,3	2,7	3,0				

Technical Datasheet - Indo Construction Fastening Systems

Rebar Ø 14									
Concrete class	C12/15	C16/20	C20/25	C25/30	C30/37	C35/45	C40/50	C45/55	C50/60
$k_b$ [-]	1,0	1,0	1,0	1,0	0,89	0,80	0,73	0,76	0,71
$f_{bd,PIR}$ [N/mm <sup>2</sup> ]	1,6	2,0	2,3	2,7			3,0		

Rebar Ø 16									
Concrete class	C12/15	C16/20	C20/25	C25/30	C30/37	C35/45	C40/50	C45/55	C50/60
$k_b$ [-]	1,0	1,0	1,0	1,0	0,89	0,80	0,73	0,67	0,63
$f_{bd,PIR}$ [N/mm <sup>2</sup> ]	1,6	2,0	2,3	2,7					

Rebar Ø 18									
Concrete class	C12/15	C16/20	C20/25	C25/30	C30/37	C35/45	C40/50	C45/55	C50/60
$k_b$ [-]	1,0	1,0	1,0	0,86	0,76	0,69	0,73	0,67	0,63
$f_{bd,PIR}$ [N/mm <sup>2</sup> ]	1,6	2,0	2,3			2,7			

Rebar Ø 20									
Concrete class	C12/15	C16/20	C20/25	C25/30	C30/37	C35/45	C40/50	C45/55	C50/60
$k_b$ [-]	1,0	1,0	1	0,86	0,76	0,69	0,63	0,58	0,54
$f_{bd,PIR}$ [N/mm <sup>2</sup> ]	1,6	2,0			2,3				

Rebar Ø 22									
Concrete class	C12/15	C16/20	C20/25	C25/30	C30/37	C35/45	C40/50	C45/55	C50/60
$k_b$ [-]	1,0	1,0	0,86	0,74	0,66	0,69	0,63	0,58	0,54
$f_{bd,PIR}$ [N/mm <sup>2</sup> ]	1,6	2,0			2,3				

Rebar Ø 24									
Concrete class	C12/15	C16/20	C20/25	C25/30	C30/37	C35/45	C40/50	C45/55	C50/60
$k_b$ [-]	1,0	1,0	0,86	0,74	0,66	0,59	0,54	0,50	0,47
$f_{bd,PIR}$ [N/mm <sup>2</sup> ]	1,6	2,0							

Rebar Ø 25									
Concrete class	C12/15	C16/20	C20/25	C25/30	C30/37	C35/45	C40/50	C45/55	C50/60
$k_b$ [-]	1,0	0,83	0,71	0,74	0,66	0,59	0,54	0,50	0,47
$f_{bd,PIR}$ [N/mm <sup>2</sup> ]	1,6			2,0					

Tabulated values are valid for good bond conditions according to EN 1992-1-1.  
For all other bond conditions multiply the values by 0,7

**Table C4**
**Amplification factor for minimum anchorage length**

Rebar	Amplification factor	Concrete class								
		C12/15	C16/20	C20/25	C25/30	C30/37	C35/45	C40/50	C45/55	C50/60
Ø8 to Ø25	$\alpha_{lb} = \alpha_{lb,100y}$	1,0	1,0	1,0	1,0	1,1	1,0	1,0	1,0	1,0

**Design values of the bond strength  $f_{bk,fi}$  and  $f_{bk,fi,100y}$  under fire exposure for working life 50 and 100 years**

The design value of the bond strength  $f_{bk,fi} = f_{bk,fi,100y}$  under fire exposure has to be calculated according the following equation:

$$f_{bk,fi}(\theta) : f_{bk,fi,100y}(\theta) = k_{fi}(\theta) \cdot f_{bd,PIR} \cdot \frac{y_c}{y_{M,fi}}$$

$$\text{if: } \begin{array}{l} 20^\circ\text{C} \leq \theta \leq 68,0^\circ\text{C} \\ > 68^\circ\text{C} \leq \theta \leq 325^\circ\text{C} \\ \theta > 325^\circ\text{C} \end{array} \quad \begin{array}{l} k_{fi}(\theta) = 1 \\ k_{fi}(\theta) = 75000 \cdot \theta^{-2,117} / (f_{bd,PIR} \cdot 4,3) \leq 1 \\ k_{fi}(\theta) = 0 \end{array}$$

$k_{fi}$  temperature reduction factor

( $\theta$ ) temperature in °C

$f_{bd,PIR}$  design value of the bond strength in N/mm<sup>2</sup> according to Table C1 considering the concrete class, the rebar diameter and the bond conditions according to EN 1992-1-1

$y_c$  partial safety factor according to EN 1992-1-1

$y_{M,fi}$  partial safety factor according to EN 1992-1-1

The anchorage length shall be determined in accordance with EN 1992-1-1 equation (8.3) using the bond strength  $f_{bk,fi}(\theta)$ .

**Table C4**

**Example of the graph of reduction factor  $k_{fi}(\theta)$  for concrete strength class C20/25 for good bond conditions**

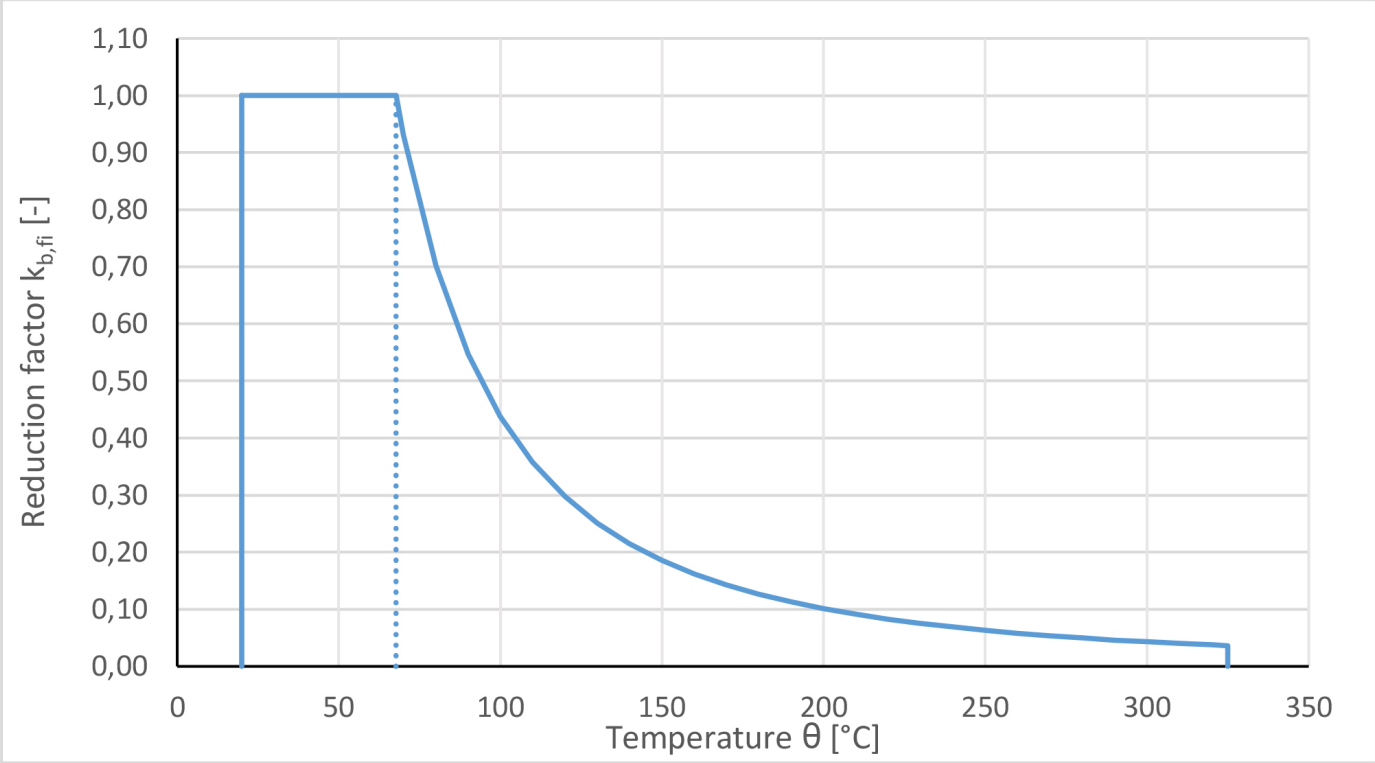

CHANNEL PARTNER



## INDO SPARK CONSTRUCTION SERVICES

### CORPORATE OFFICE

198, E ward, Tararani Chowk,  
Near Geeta Mandir,  
Kolhapur - 416 003 (Mah.India)  
Toll Free : 1800 123 500 023  
E-mail : mail@indospark.com

### BRANCHES

Pune | Mumbai

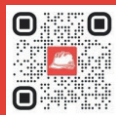

FOLLOW US



www.indospark.com